



## TITAN Superstruts

The first choice for every trench shoring job



- **Superstrut Gi-SV**  
TBG 3-Gi-SV
- **Superstrut Gi-S**  
TBG 3-Gi-S
- **Spindle/strut heads Gi-SV-I**  
TBG 3-Gi-SV-I
- **Trench strut TITAN 60**  
TBG 3-TI
- **Medium duty strut TITAN 48**  
TBG 3-Gi-L
- **Light duty struts „terra“**  
TBG 3-terra
- **TITAN wedge clamps**

...approved according to DIN 4124 by the German Civil Engineering Employers' Insurance Liability Association (TBG) – a legal requirement since 1 January 1982

What that means for you is:

- No problems during the acceptance inspection
- Quality-tested as part of the quality control contract with the Material-Testing Institute of North Rhine-Westphalia



**Trench strut TITAN 60** for safe working loads from 70 to 100 kN. In wide and deep trenches (large drains, sewers, etc.), generous strut spacings simplify excavation work and pipelaying. The TITAN 60 trench strut is suitable for the vertical trench sheeting often used in such situations. With angle end plates for 140 x 160 mm timber walings.

- Length infinitely adjustable over 600 mm
- Just one Ø 60 mm spindle fits all strut sizes
- Fast-action thread: 10 mm length adjustment for each turn
- Releasing the strut requires only half the effort
- Spindle and tube interchangeable, but permanently coupled together when in use

Trench strut TITAN 60 to DIN 4124

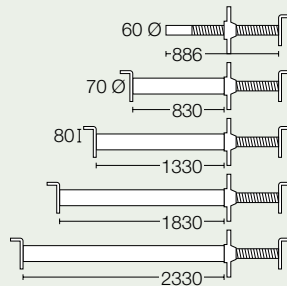

weight app. kg	adjustment app. m	perm. load kN	description
10	0.60	-	Ti 60 Spindel
17	0.90 - 1.50	100 - 99	Ti 60/150
20	1.40 - 2.00	100 - 93	Ti 60/200
23	1.90 - 2.50	95 - 84	Ti 60/250
26	2.40 - 3.00	85 - 72	Ti 60/300

**Medium duty strut TITAN 48** for safe working loads from 38 to 63 kN. Our best-selling strut for the most common trench widths of 1.0 – 1.5 m. With angle end plates for 140 x 160 mm timber walings.

- Length infinitely adjustable
- Easy to use with high loads
- Spindle and tube interchangeable, but permanently coupled together when in use

Medium duty strut TITAN 48 to DIN 4124

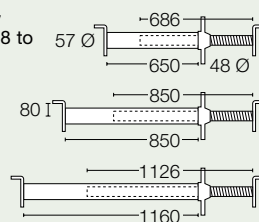

weight app. kg	adjustment app. m	perm. load kN	description
8	0.70 - 1.17	63 - 48	Ti 48/120
10	0.90 - 1.50	61 - 45	Ti 48/150
13	1.20 - 2.10	60 - 38	Ti 48/210

**Light duty strut "terra"** for safe working loads from 22 to 38 kN. Ideal for use with horizontal, timber trench lining systems in narrow trenches (e.g. building service lines, manual excavation for repairs, etc.). With claw end plates and nailing holes.

- Length infinitely adjustable over 300 mm
- Tubular steel spindle Ø 32 mm is 40% lighter than a solid spindle for the same load
- Hardened thread can withstand tough, dirty working conditions
- Spindle and tube interchangeable, but permanently coupled together when in use

Light duty strut "terra" to DIN 4124

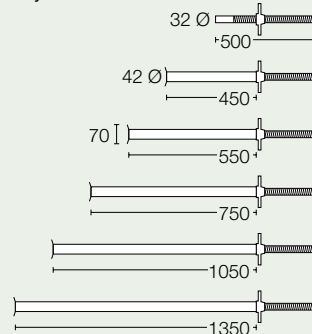

weight app. kg	adjustment app. m	perm. load kN	description
2.1	30	-	terra Spindel
3.6	0.50 - 0.80	38 - 30	terra Gr. 1
4.0	0.60 - 0.90	36 - 29	terra Gr. 1a
4.6	0.80 - 1.10	34 - 29	terra Gr. 2
5.5	1.10 - 1.40	29 - 23	terra Gr. 3
6.5	1.40 - 1.70	26 - 22	terra Gr. 4

#### Instructions for using trench struts to DIN 4124 (These instructions must be available on the building site.)

##### Conditions of use for steel bracing elements

1. Use bracing elements only for the purpose for which they are intended.
2. Prior to use, always check the condition of bracing elements. Never use damaged elements.
3. Do not exceed the stated safe working load (SWL).
4. Do not support loads on or suspend loads from bracing elements.
5. Bracing elements may only be assembled from parts marked with the same approval marking.
6. When setting up the trench shoring, always position the spindles alternately on the left and right sides of the trench. This method ensures that the weakest parts of the entire trench shoring system do not all lie in one and the same vertical plane.
7. To achieve a concentric loading, install the bracing elements so that their end plates fit tightly against the trench lining elements. If the trench sides are not parallel, this lack of alignment must be compensated for by using hardwood wedges.
8. Make sure that any anti-corrosion coating on the bracing elements remains intact. Apply a generous amount of grease to all threaded parts.
9. Trench struts must be marked with the inspection number of the German Civil Engineering Employers' Insurance Liability Association (TBG) and the manufacturer's designation.
10. Trench struts must be checked once a year in the company by a trained person according to the manufacturer's instructions.
11. Adjustable steel props designed for vertical support applications may not be used as an alternative to trench struts in civil engineering applications.

**Superstrut Gi-SV** for safe working loads from 258 to 548 kN, with end hooks for HEB 140 – 300 steel sections.



- Length infinitely adjustable over 700 mm
- Just one Ø 100 mm spindle fits all strut sizes
- Self-centring end hooks for HEB steel walings
- End hooks optimally secured against slipping and twisting

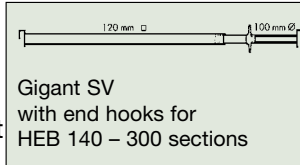

Type	Description	adjustment	perm. load	weight
Inspection No.		approx. m	kN	approx. kg
Trench strut	Gi-SV-210	1,40-2,10	548-290	69
Gigant SV	Gi-SV-260	1,90-2,60	471-260	81
TBG 3-Gi-SV	Gi-SV-310	2,40-3,10	424-270	92
	Gi-SV-380	3,10-3,80	390-258	107
	Gi-SV-450	3,80-4,50	344-262	122

**Superstrut Gi-S** for safe working loads from 138 to 210 kN, with end hooks for HEB 140 – 240 steel sections.



- Self-centring end hooks for HEB steel walings
- End hooks optimally secured against slipping and twisting

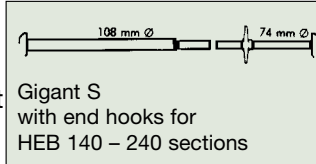

Type	Description	adjustment	perm. load	weight
Inspection No.		approx. m	kN	approx. kg
Trench strut	Gi-S-120	0,70-1,20	210-177	26
Gigant S	Gi-S-170	1,05-1,70	210-177	32
TBG 3-Gi-S	Gi-S-210	1,40-2,10	184-156	35
	Gi-S-260	1,90-2,60	176-140	40
	Gi-S-310	2,40-3,10	157-138	45

**Spindle/strut heads Gi-SV-I** with end hooks for steel walings up to HEB 300 designed for bolting (M16) or welding to the web of a steel section (HEB 140 – 200).



- Self-centring end hooks for HEB steel walings
- End hooks optimally secured against slipping and twisting

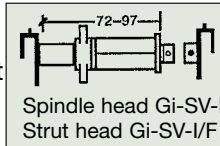

Type	Description	adjustment	perm. load	weight
Inspection No.		approx. m	kN	approx. kg
Spindle head	Gi-SV-I	0,72-0,97	448-393	50,0
Strut head	Gi-SV-I/F	–	448-393	5,0
TBG 3-Gi-SV-I				

**Loading diagram for superstruts**

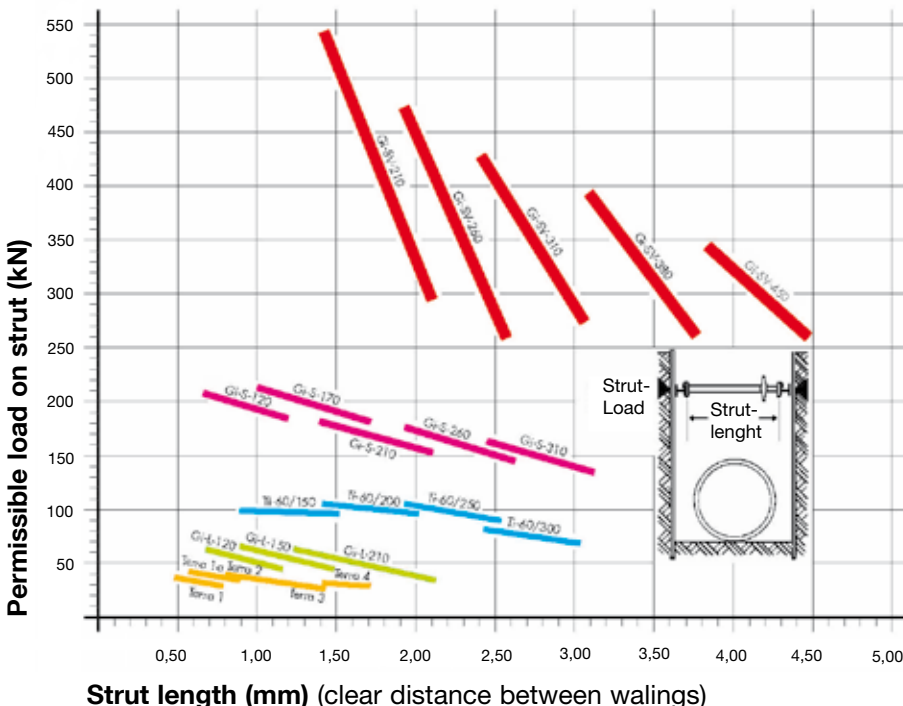

The end hook guarantees that waling and strut axis always align.



## TITAN Wedge Clamps

Max. permissible load 10 kN

For trench lining systems with timber planks and TITAN wedge clamps

Suitable for deep trenches (5 – 8 m) in urban locations.

- Preliminary excavation without trench lining down to a depth of 1.25 m – no problem with the majority of buried services.
- Insertion of posts (e.g. HEB beams) into augured holes and driving to full depth – no noise problems.
- Positioning the timber planks in front of the steel posts saves expensive manual excavation between the posts (the normal situation with a soldier pile wall).
- Timber lining easy to handle and easy to cut where services cross the excavation.
- TITAN Wedge Clamps are suitable for plank thicknesses of 50 - 80 mm and HEB 100 – 280 steel sections.
- Number of wedge clamps required:  
spacing of steel posts = 2.25 m, 1.4 pcs./m<sup>2</sup>  
spacing of steel posts = 1.50 m, 1.8 – 2.0 pcs./m<sup>2</sup>

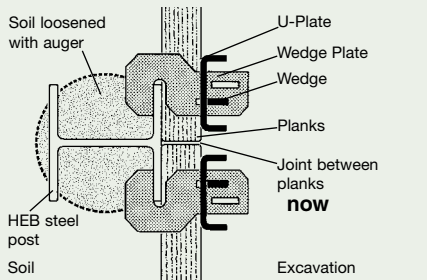
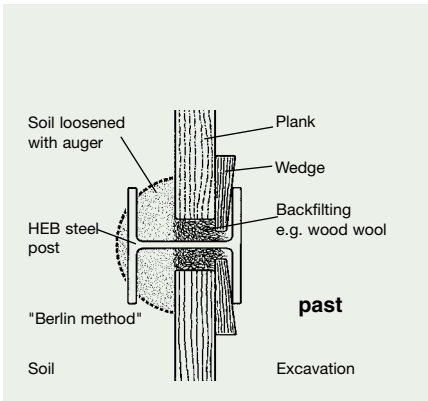
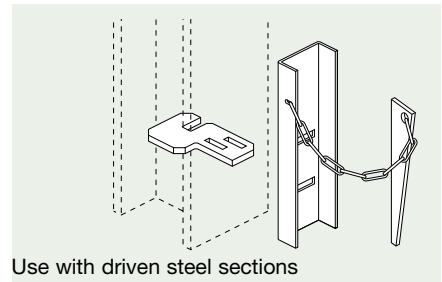
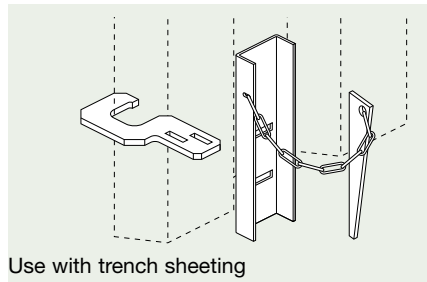
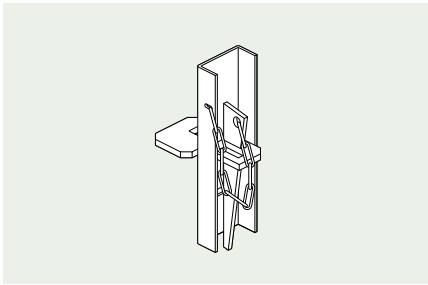

Price comparison: (as of 2002)

**Soldier pile wall with wedge clamps:**

approx. 96 – 116 €/m<sup>2</sup>

**Soldier pile wall**

**(standard "Berlin method"):**

approx. 140 – 165 €/m<sup>2</sup>

DIN EN ISO 9001

CERTIFIED QUALITY SYSTEM

**DVS**  
Z E R T

DIN EN ISO 9001 / 2000  
Zertifiziert durch DVS ZERT® e. V.  
Registriernummer DE-96-010

**ISCHEBECK**®

... technically advanced formwork, shoring,  
trenching and geotechnical systems

FRIEDR. ISCHEBECK GMBH · P.O. Box 13 41 · DE-58242 ENNEPETAL · GERMANY

☎ + 49 - 2333 - 83 05-0 · FAX + 49 - 23 33 - 83 05-55 · E-MAIL: export@ischebeck.de · INTERNET: www.ischebeck.com

principal office Ennepetal · register court Hagen HRB 5585 · VAT Id.No.: DE811161225 · joint managing directors: Dipl.-Ing. Ernst Friedrich Ischebeck, Friedrich Döpp, Dipl. Wi.-Ing. Björn Ischebeck



Megashore



HV-System



Slabforming  
Systems

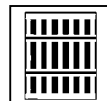

Wallform

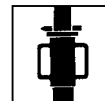

Props

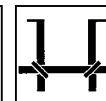

Beam  
Forms

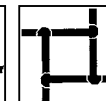

Column  
Forms

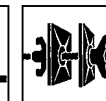

Formwork  
Ties

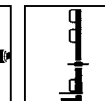

Rail Posts

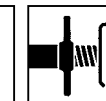

Struts

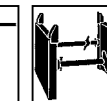

Trenching  
Systems

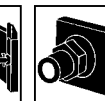

Geotechnical  
Systems