

H20 multi clamp (aluminium)

Fast connection to all beams whilst giving resistance to horizontal formwork loads.

advantages:

- 1/3 of the weight of traditional flange clamps
- easy handling and fixing by one person
- timber beams can be moved sideways through the open hinged jaw of the clamp
- a pressure spring correctly positions the clamp jaws
- clamp aligns beams at right angles
- timber beams are not damaged by screws thus eliminating damage costs on rental equipment

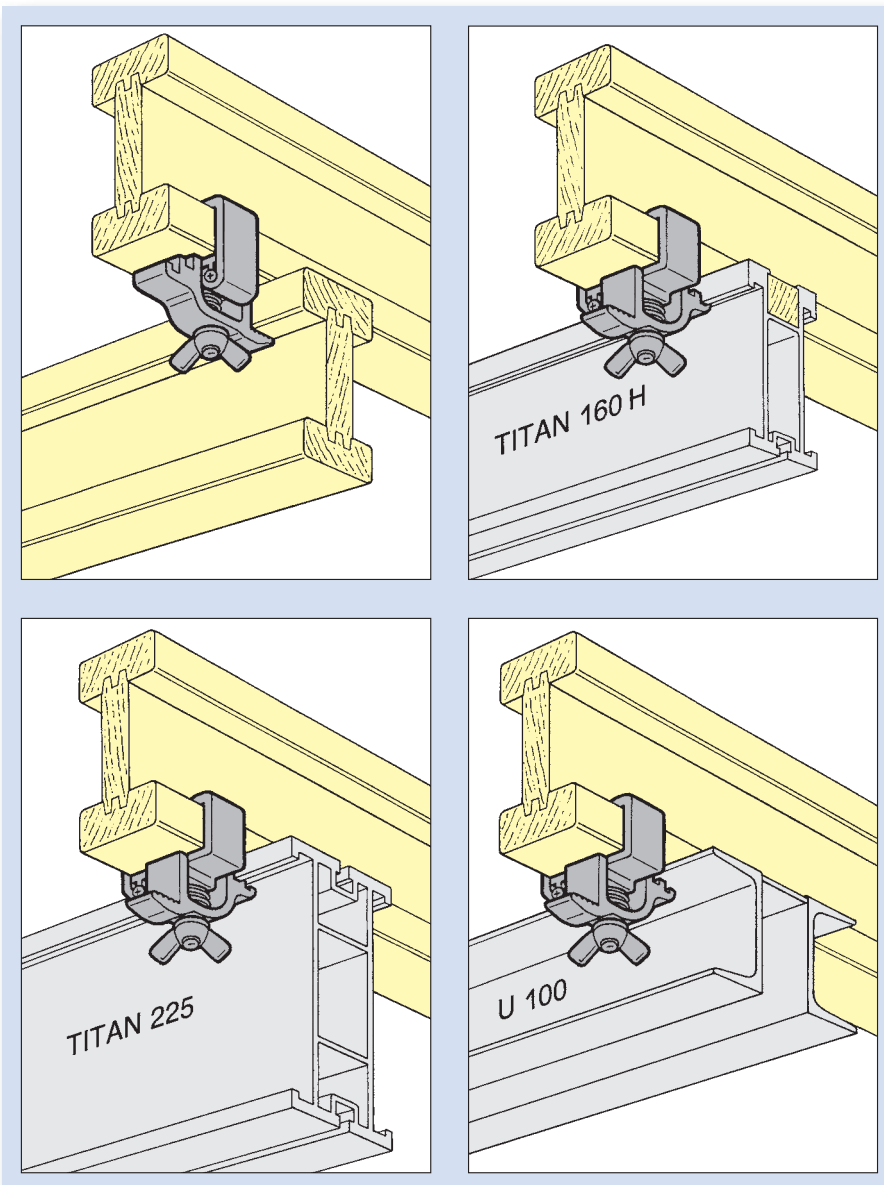

H20 multi clamp (aluminium)



Technical data:

weight per clamp: 0,35 kg
 tightening torque: 50 Nm
 perm. horizontal slip load: 2,5 kN
 perm. tensile load: 5 kN



ISCHEBECK® ... technically advanced formwork, shoring, trenching and geotechnical systems



DIN EN ISO 9001
 Zertifiziert durch DVS ZERT® e.V.,
 Registernummer DE-96-010

FRIEDR. ISCHEBECK GMBH · P.O. BOX 13 41 · 58242 ENNEPETAL · GERMANY

☎ + 49 - 23 33 - 8 30 5 0 · FAX + 49 - 23 33 - 83 05 55 · E-MAIL: export@ischebeck.de · INTERNET: www.ischebeck.com



Megashore HV-System Slabforming Systems Wallform Props Beam Forms Column Forms Formwork Ties Rail Posts Struts Trenching Systems Geotechnical Systems